

## seaFAST REE ICPMS for Preconcentration and Detection of Rare Earth Elements in Undiluted Seawater

Nathan Saetveit and Dan Wiederin

Elemental Scientific

### Introduction

ESI's seaFAST is a fully-automated online system that improves elemental detection limits in undiluted seawater by both preconcentrating analyte and eliminating matrix components. The seaFAST is well-established for determining transition metals in coastal and open-ocean seawaters. This note explores the effectiveness of the seaFAST system in detecting ppq and low ppt concentrations of rare earth elements (REE) in seawater.

With the seaFAST, targeted elements from an aliquot of sample are trapped on a mixed resin preconcentration column while the matrix ions, such as  $\text{Na}^+$  and  $\text{Cl}^-$ , pass through to waste. Nitric acid then elutes the concentrated metals from the column into the ICPMS nebulizer. The seaFAST system automates the entire process, eliminating the time-consuming and contamination-prone steps involved in manual preconcentration and matrix removal.

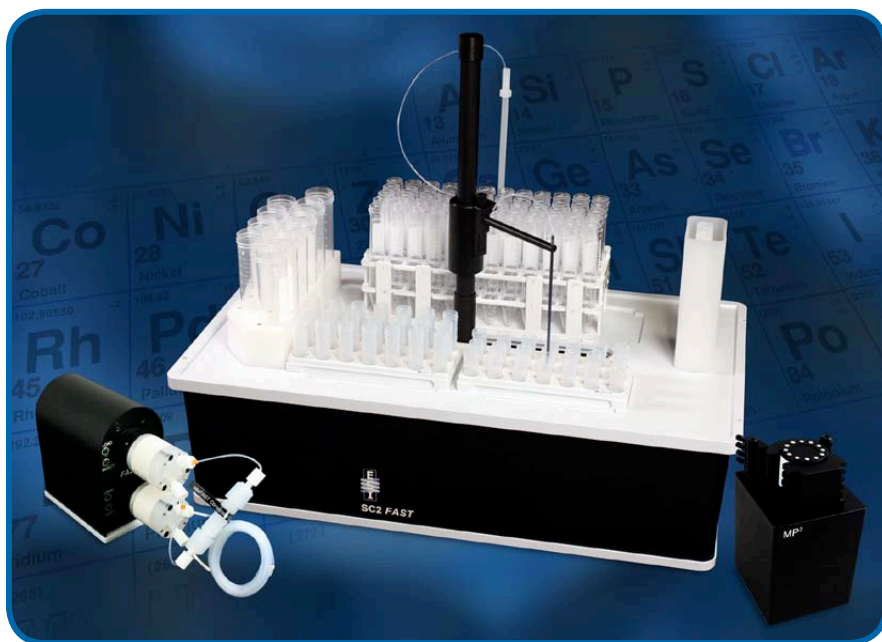

seaFAST Preconcentration and Matrix Removal System

## Experimental

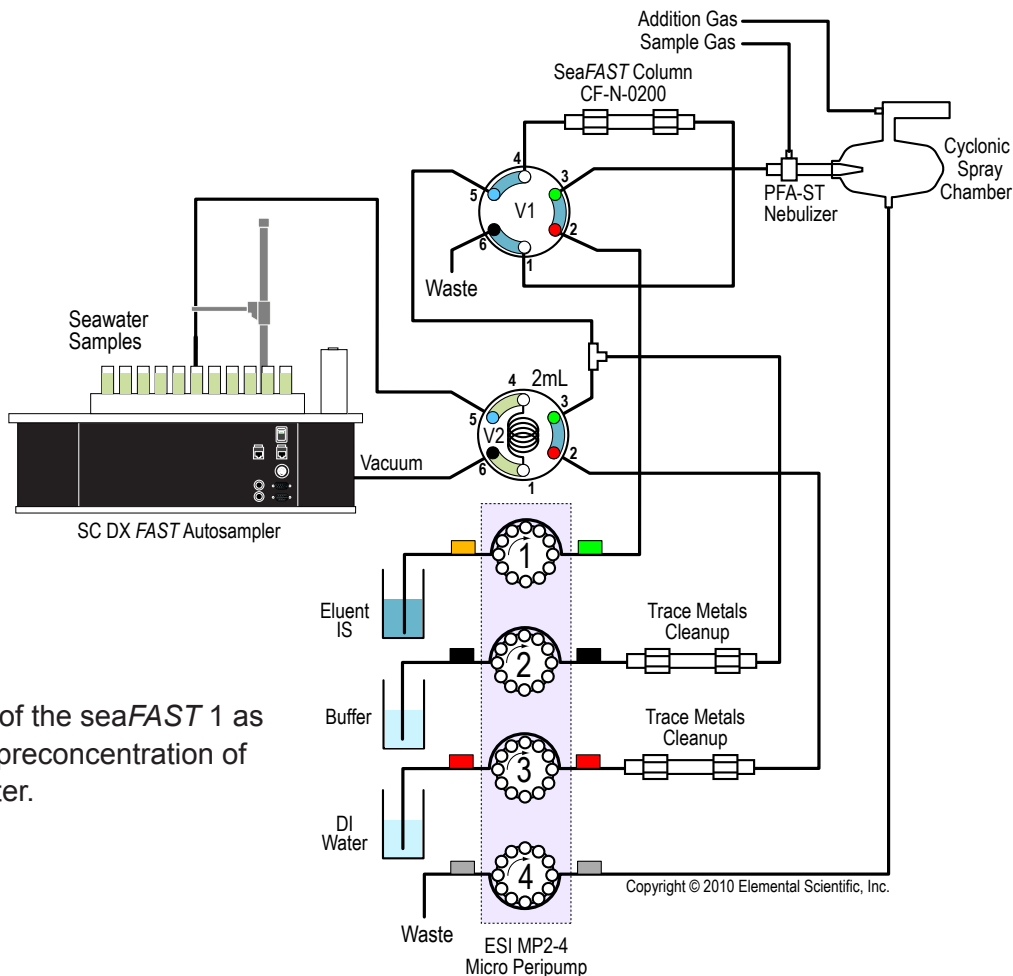

**Fig 1.** Diagram of the seaFAST 1 as used for online pre-concentration of REEs in seawater.

**Table 1. ICPMS Conditions**

ICPMS Instrument	Thermo Element2
RF Power	1400 W
Nebulizer Gas Flow	0.7 L/min
Plasma Gas Flow	16 L/min
Auxiliary Gas Flow	0.9 L/min
Additional Gas Flow	0.15 L/min
Resolution	Low
Number of Isotopes	22
Scan Conditions	17 runs, 1 pass, 2 seconds per pass

**Table 2. seaFAST Conditions**

seaFAST Version	1
Preconcentration Column	seaFAST (CF-N-0200), PFA hardware
Peripump	ESI MP2-4 microperipump
Carrier Flow Rate	200 $\mu$ L/min
Sample Loop Volume	4 mL

## Procedure

Calibration standards were prepared in 1% nitric acid. The pre-acidified (pH 2) seawater samples (NASS-5) were analyzed neat. The sample was vacuum-loaded into a loop and injected onto the column. After pre-concentration and matrix removal in the column, the REEs were eluted from the column directly into the ICPMS by 8% HNO<sub>3</sub> (v/v), and the column was reconditioned prior to analyzing the next sample.

## Results

**Calibration curves.** Calibration standards measured in 1% HNO<sub>3</sub> acid show excellent linearity from ppq to >10 ppb. Shown here is the low end of the calibration curve.

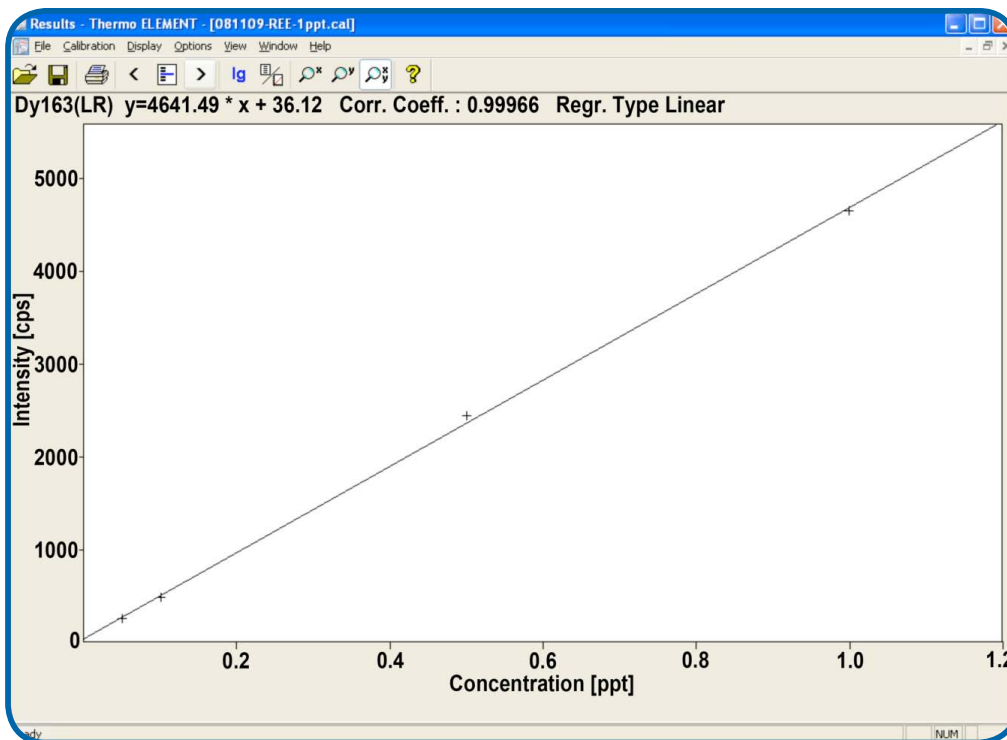

Figure 2. Calibration curve for Dysprosium from 50 ppq to 1 ppt.

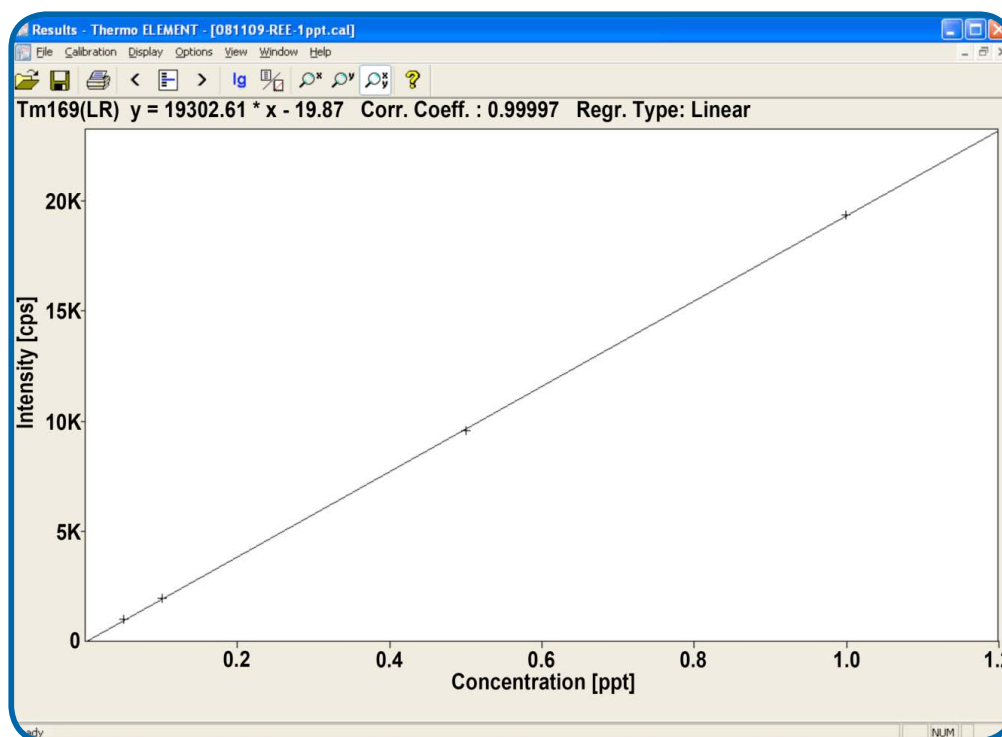
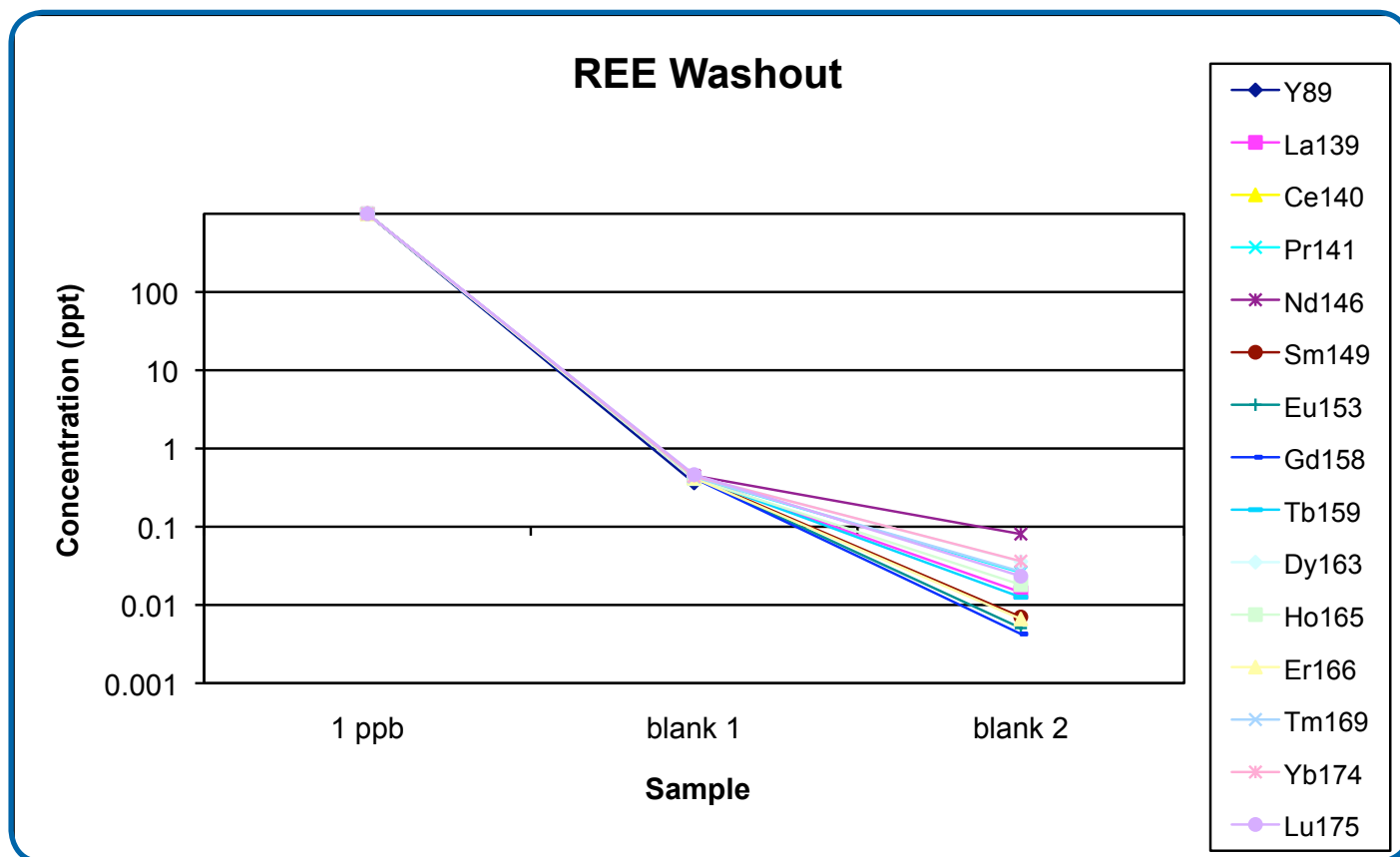

Figure 3. Calibration curve for Thulium 50 ppq to 1 ppt.

**Washout.** Washout data demonstrates the ability of seaFAST to automatically and sequentially analyze samples with a range of concentrations.



**Figure 4.** Carryover after 1 ppb sample. The seaFAST system has low carryover and fast washout. First blank after a 1 ppb washed out > 3 orders of magnitude. Second blank washed out more than 4 orders of magnitude.

**Detection Limits.** Analytical detection limits (3 times the standard deviation of seven consecutive blanks) are shown in Table 3. The DL for each of the REEs are all in the low ppq range. Further improvement in DL may be achieved by using an Apex sample introduction system.

Table 3. Detection limits ( $3\sigma$ ) for rare earth elements	
Analyte	LOD (ppq)
Y	12
La	29
Ce	16
Pr	5
Nd	21
Sm	11
Eu	4
Gd	6
Tb	3
Dy	6
Ho	5
Er	7
Tm	3
Yb	5
Lu	4

**CRM Results.** NASS-5, a certified reference material (CRM) collected southwest of the coast of Nova Scotia, Canada, was analyzed to verify system performance. All concentrations are within expected range (Table 4).

Table 4. Comparison of reference NASS-5 results and ESI seaFAST results in ppt		
Analyte	seaFAST <sup>1</sup>	Reference <sup>2</sup>
Y	24.17 ± 0.07	22.00 ± 2.90
La	12.55 ± 0.02	12.19 ± 1.14
Ce	5.93 ± 0.0002	5.72 ± 0.69
Pr	2.13 ± 0.01	2.09 ± 0.19
Nd	8.8 ± 0.3	8.43 ± 0.65
Sm	4.54 ± 0.02	4.74 ± 0.34
Eu	0.32 ± 0.001	0.33 ± 0.03
Gd	1.95 ± 0.07	1.83 ± 0.15
Tb	0.25 ± 0.02	0.27 ± 0.03
Dy	1.88 ± 0.02	1.82 ± 0.20
Ho	0.42 ± 0.02	0.47 ± 0.06
Er	1.4 ± 0.04	1.43 ± 0.20
Tm	0.2 ± 0.03	0.21 ± 0.04
Yb	1.14 ± 0.04	1.29 ± 0.38
Lu	0.2 ± 0.03	0.19 ± 0.06

<sup>1</sup> Present work

<sup>2</sup> M. G. Lawrence and B. S. Balz, Geostand. Geoanal. Res. 2007, 31, 95-103.

## Conclusion

With the online capabilities of the seaFAST, rapid and accurate results at low to sub-ppt concentrations in undiluted seawater can be achieved, eliminating time-consuming manual sample preparation and the associated procedural blanks. Excellent agreement with reference values for REEs in NASS-5 seawater, fast washout characteristics and low ppq detection limits demonstrate that the seaFAST is a robust and completely automated solution for labs measuring REEs in seawater samples.