

# Analysis of Undiluted Seawater

## Preconcentration and Matrix Removal

### Introduction

The direct analysis of seawater by ICPMS is difficult due to the high matrix content and very low desired detection limits. Various strategies have been used to analyze seawater samples, including dilution, direct analysis at low flow rates, and manual preconcentration and matrix removal with chelating beads. Many of these techniques are laborious and prone to contamination due to sample handling and are not well-suited for routine analysis of seawater.

The seaFAST system addresses common problems with seawater analysis by using an entirely automated preconcentration and matrix elimination process. Detection limits in undiluted seawater are improved by more than an order of magnitude for critical trace elements, and all sample preparation steps are eliminated.

The seaFAST system preconcentrates elements such as Ti, Co, Ni, Cu, Zn, Cd, and Pb, as well as rare earth elements, but allows seawater matrix ions Na, Cl, Mg, and Ca to pass through to waste. After preconcentration, analytes are eluted into an ICPMS. Since the matrix has been removed, seawater-related polyatomic interferences and matrix suppression are not observed.

The seaFAST system also preconcentrates the following elements: Al, Sc, V, Mn, Fe, Ga, Y, Zr, Nb, Mo, Pd, Ag, In, Sn, La, Ce, Pr, Nd, Sm, Eu, Gd, Tb, Ho, Er, Tm, Yb, Lu, Hf, Ta, W, Re, Os, Ir, Pt, Bi, Th, and U.

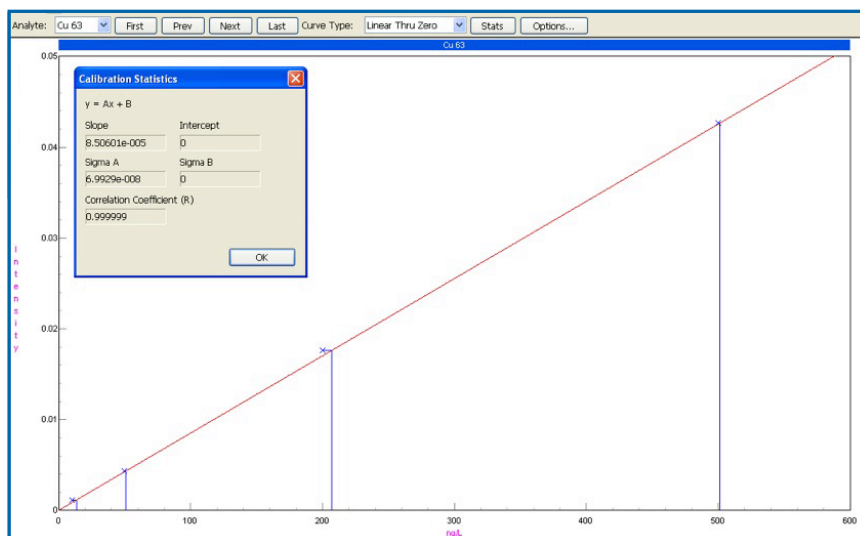
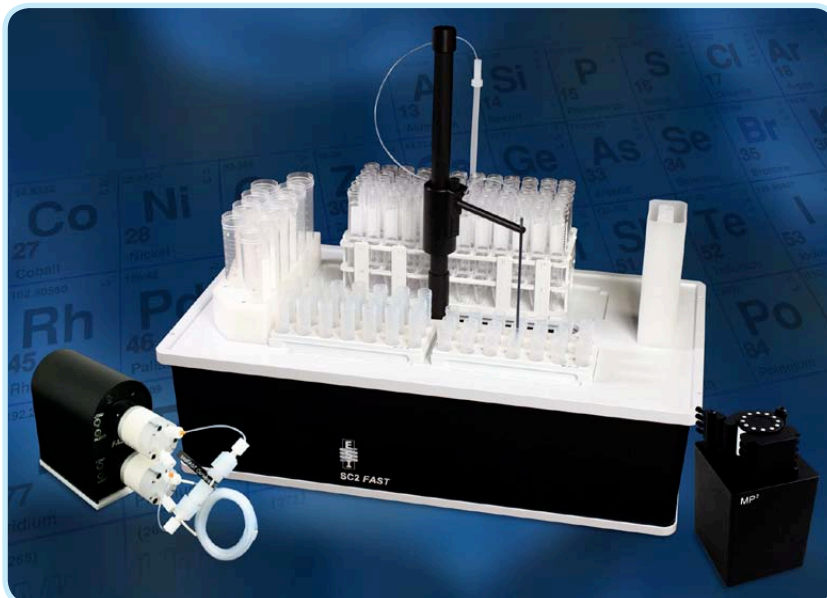

**Calibration of Cu in Undiluted Seawater. Calibration spikes are 10, 50, 200, 500, and 5000 ppt. Without matrix removal, a large Na interference would be present.**

## Experimental

### Sample Introduction

The following components were used with the fully-automated seaFAST sample introduction system:

- High-purity SC-Autosampler
- Dual flowing rinse stations
- Two high-purity fluoropolymer injection valves
- Iminodiacetate (IDA) chelation column
- High-efficiency PFA-ST nebulizer
- Inert o-ring-free spray chamber
- Sapphire injector

Two milliliters of undiluted seawater samples was analyzed. Sample volume may be adjusted, however, to obtain desired detection limits.

## Instrumentation – ICPMS

A PerkinElmer ELAN ICPMS in normal mode (no DRC) acquired all data. Read delay on the ICP instrument was set to synchronize data acquisition with the elution event. The ICP instrument software prepares the calibration curve and calculates concentrations as it would for a normal, continuous flow analysis.

## Software Settings

The seaFAST system is fully-integrated with the ELAN software—offering control of both introduction and ICPMS operating parameters, and all settings necessary to automate chelation/preconcentration of metal contaminants in seawater samples.

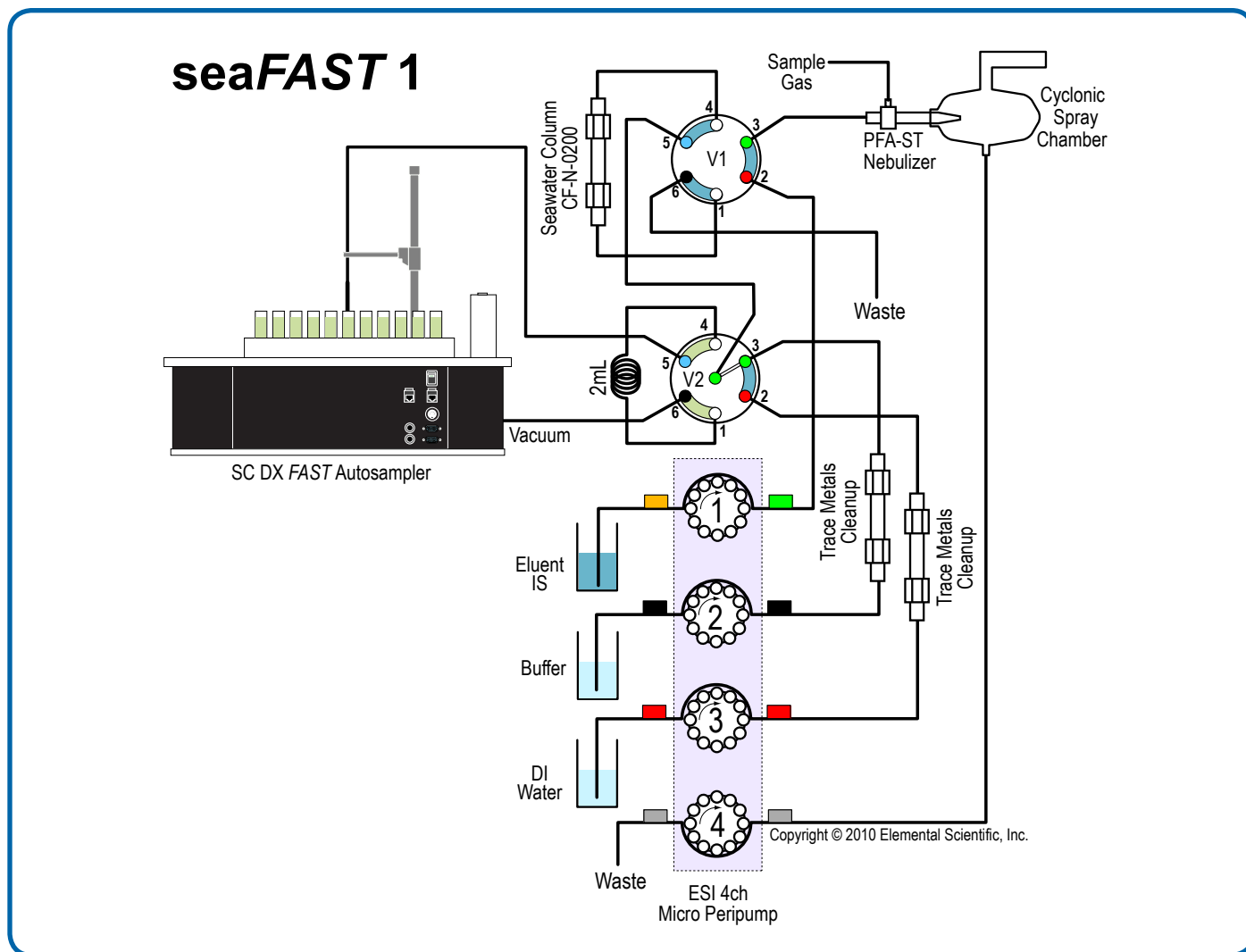

seaFAST Automated Seawater Matrix Removal System Diagram

| Steps   | Time (min)     |
|---|----------------|
| Load seawater sample onto preconcentration column | 2              |
| Wash column remove matrix                         | 3              |
| Acid elute concentrated metals from column        | 1              |
| Autoclean column prior to next sample             | 3              |
| <b>TOTAL TIME PER SEAWATER SAMPLE</b>             | <b>~ 9 min</b> |

**Table 1.** Steps for Automated IDA Chelation for Seawater Analysis

| Method Detection Limits (MDL) |          |
|-------------------------------|----------|
| Analyte                       | MDL, ppt |
| Ti                            | 5        |
| V                             | 1        |
| Co                            | 0.5      |
| Ni                            | 2        |
| Cu                            | 3        |
| Zn                            | 6        |
| Mo                            | 4        |
| Cd                            | 1        |
| Sn                            | 2        |
| Pb                            | 2        |

**Table 2.** Method Detection Limits

| R <sup>2</sup> Values (Seawater) |                |
|----------------------------------|----------------|
| Analyte                          | R <sup>2</sup> |
| Ti                               | 0.999998       |
| Co                               | 0.999998       |
| Ni                               | 0.999998       |
| Cu                               | 0.999999       |
| Zn                               | 0.999982       |
| Cd                               | 0.999999       |
| Pb                               | 0.999983       |

**Table 4.** Calibration coefficients for curves including 10, 50, 200, 500, 5000 ppt spikes

| Spike Recoveries (%) in NASS-5 Seawater |         |
|---|---------|
| Analyte                                 | 200 ppt |
| Ti                                      | 99      |
| Co                                      | 102     |
| Ni                                      | 103     |
| Cu                                      | 111     |
| Zn                                      | 109     |
| Cd                                      | 94      |
| Pb                                      | 97      |

**Table 3.** Spike recoveries shown from ppt-level spikes in NASS-5 Seawater

## Conclusion

The seaFAST system is an entirely automated solution for the analysis of undiluted seawater that offers improved detection limits with much less sample preparation compared to conventional seawater analysis.

Low-ppt detection limits and excellent spike recoveries in NASS-5 seawater were obtained with a sample-to-sample time less than 10 minutes.

The seaFAST system is ideal for labs that want superb detection limits with little or no sample preparation.