

hydrideFAST 2

Simultaneous Nebulization and Hydride Generation

hydrideFAST is an online sample introduction system that minimizes the complexity of previous hydride generators while offering high sensitivity. The hydrideFAST 2 version can simultaneously generate both nebulized sample aerosol and hydride gases, introducing both into an ICP instrument at the same time for maximized sensitivity and productivity. At the heart of the hydrideFAST are two key components: the **MP² Precision Micro Peripump** and the patent-pending **hydrideFAST Gas Liquid Separator**.

MP² Peripump

Designed with ICP and ICPMS applications in mind, the MP² micro peripump uses a combination of acid-resistant ceramic pins with long-life precision polymer rollers to deliver sample and reagents smoothly at flow rates ranging from sub microliter-per-minute to > 10 milliliters per minute.



Gas Liquid Separator

ESI has developed the smallest, highest-performing and most stable gas liquid separator on the market for the hydrideFAST system. All connections are conveniently and securely made using threaded quartz connectors. The design promotes rapid mixing of sample with hydride reagents, promoting a more complete reaction and separation of hydride gases from sample liquids in a small volume.

Measure All ICP Elements Plus Hydride Generation

Traditionally, analyzing hydride-forming elements requires a dedicated machine, meaning all non-hydride elements present in the sample cannot be measured. But with hydrideFAST 2, all elements can be analyzed at the same time with a single instrument. This allows for fewer and faster sample runs.

The Highest Level of Stability

With other systems, the amount of hydrogen gas formed over time can vary, causing issues with system sensitivity. The MP² pump on the hydrideFAST system ensures precision addition of hydride reagents providing constant formation of both analyte hydrides and hydrogen gas, promoting a remarkably stable ICP signal and further improved detection limits.

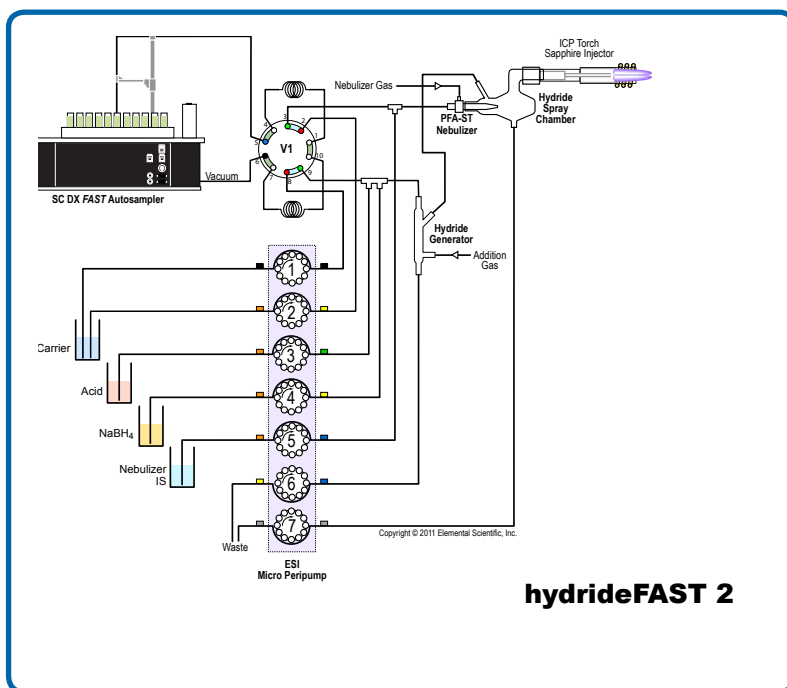

Figure 1. A diagram of the hydrideFAST 2 system with two sample loops for FAST hydride generation and simultaneous nebulization of liquid samples

Features and Benefits of hydrideFAST

Feature	Benefits
MP ² Peripump	• Stable signal for improved detection limits • Stable hydrogen gas formation
Gas-Liquid Separator	• Enhances sensitivity • Small internal volume for low memory effect and fast washout
Small Size	• Conserves lab space
Integrated, Modular Design	• Tames tubing • Built-in connections
Flexible	• 3 modes of operation

Example ICP Detection limits (3σ) for hydride-forming (black) and non-hydride (blue) elements in hydrideFAST mode

Analyte	As	Se	Hg	Sb	Ti	Mn
DL (ppb)	0.08	0.1	0.1	.03	0.1	0.1

With hydrideFAST, extremely low levels of hydride-forming elements can be detected. Calibration curves for As, Se, Sb, and other hydride-forming elements measured with NaBH₄ show excellent linearity from 0 to 10 ppb. Hg curves, which showed similar linearity, were measured with SnCl₂.

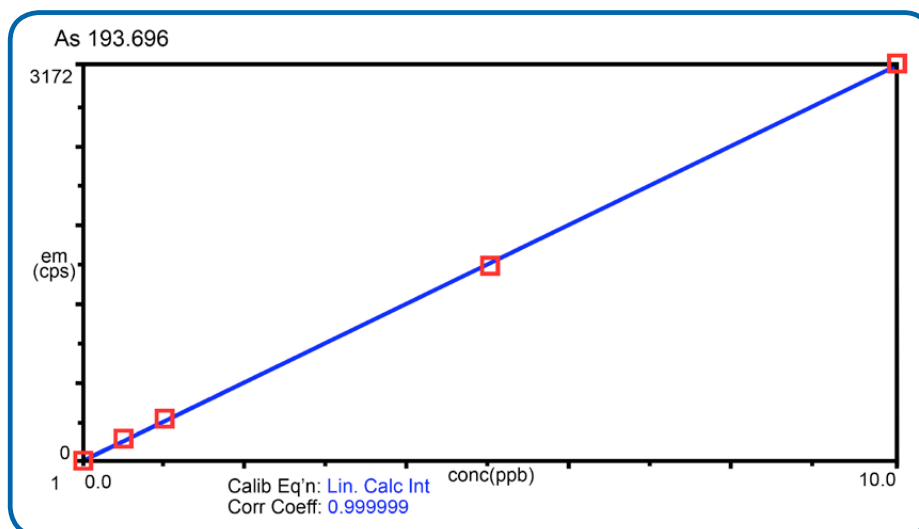

Calibration curve for As. Calibration points at 0, 0.5, 1, 5, and 10 ppb.

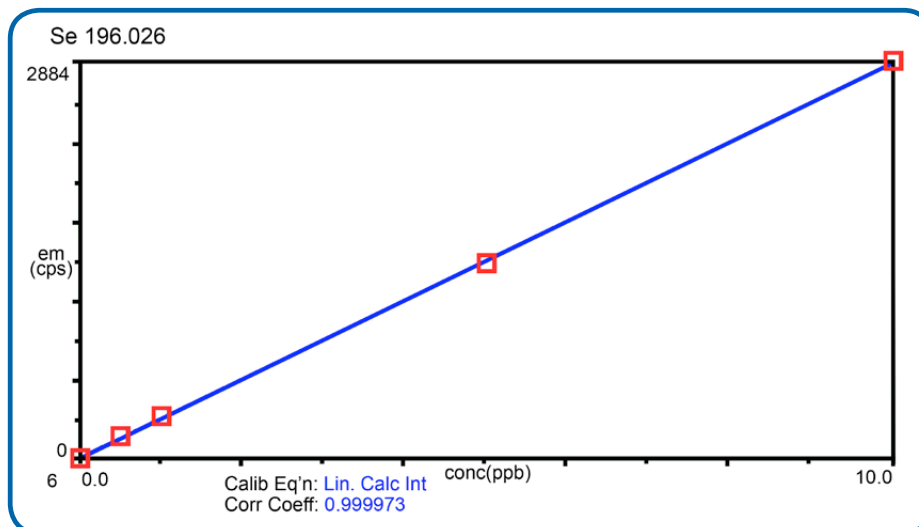

Calibration curve for Se. Calibration points at 0, 0.5, 1, 5, and 10 ppb.

The hydrideFAST 2 system has at least three modes of operation. Switching among the three modes takes only a few minutes and allows optimized application-specific procedures.

1 hydrideFAST 2 mode (hydride generation and nebulization)

In this mode the FAST system is equipped with a valve with two sample loops. During each run, the contents of one loop are nebulized into the ICP spray chamber while the contents of the second loop are directed to the hydride generator where hydride-forming elements are converted to gaseous hydrides. The hydrides are combined with the nebulized aerosol and injected into the ICP.

Advantages: Measures all of the sample simultaneously: The sensitivity for hydride-forming elements can be higher than either hydride alone or nebulization alone because both hydride gases and nebulized aerosol contribute to the analytical signal. This mode maintains the high-throughput productivity of the FAST system while producing high sensitivity and low detection limits for hydride-forming elements including As, Se, Sb, and Hg.

Disadvantages: Hydride reagents must be added to the hydrideICP in hydrideFAST mode. If low detection limits for hydride-forming elements are not required, then these reagents can be saved by operating in standard FAST mode.

2 hydrideFAST 1 mode (hydride generation only)

In this mode the FAST valve is configured with one sample loop that is loaded and then injected into the hydride chamber, efficiently converting hydride-forming elements such as As, Se, Sb, and Hg into gaseous hydride which are injected into the ICP for detection.

Advantages: High sensitivity for hydride-forming elements only. In addition, because the sample is loaded into the FAST valve, memory effects are reduced compared to conventional hydride generation systems.

Disadvantages: In this mode, non-hydride forming elements are not detected.

3 FAST mode (nebulization only)

The FAST-only mode operates as a high-throughput sample introduction system—the most advanced and most integrated system available.

Advantages: High throughput ICP with low memory effects and small sample consumption.

Disadvantages: Standard sensitivity for hydride-forming elements.