

Mobile Stand for SC-2 DX Autosampler

The mobile stand for the SC-2 DX Autosampler secures and positions the SC-2 DX, eliminating the need for an autosampler table. The SC-2 DX mobile stand offers many other benefits.

Benefits

- **Convenient** – Autosampler, pumps, rinse and waste bottles contained in a single unit
- **Compact** – Footprint only slightly larger than autosampler itself, saving valuable lab space and maintaining accessibility to sample racks
- **Attractive** – Stand eliminates need for separate table.
- **Mobile** – Locking wheels easily unlatch to move autosampler for instrument maintenance
- Eliminates unnecessary external connections to rinse solution and waste reservoirs
- The intermediate shelf can be used to support automation options such as syringe pumps or for storage of optimization solutions.
- The lower shelf holds rinse solution and waste bottles and allows the rinse container to be refilled in place.
- Integrated enclosure with or without ULPA filtered environment



SC-2 DX on Mobile Stand



Accessible rinse bottle can be refilled in place



Storage space for racks and solutions

**Mobile Stand for SC-2 DX
Autosampler (stand only)**

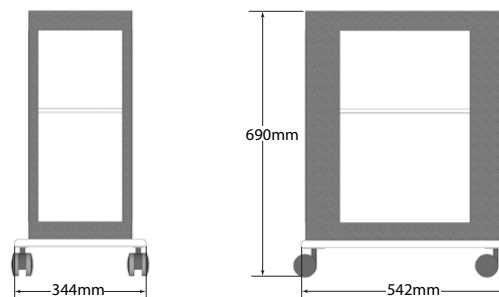

**Mobile Stand with SC-2 DX
Autosampler**

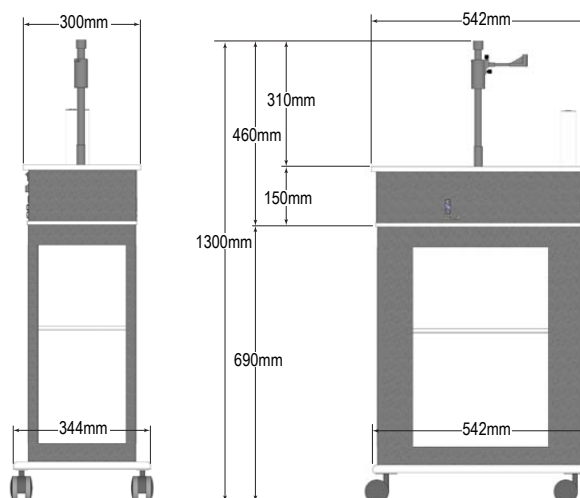

**Mobile Stand with SC-2 DX
Autosampler and Enclosure**

